

ITEM NO.	QTY.	PART NO.	DESCRIPTION
1	1	BH-001	Boring head body
2	1	BH-002	slide
3	1	BH-003	Gib
4	1	BH-004	Nut
5	1	BH-005	Dial
6	1	BH-006	HX-SHCS 0.138-40x1.25x1.25-N
7	1	BH-007	Dial Retainer
8	3	BH-008	SSCUPSKT 0.164-32x0.1875-HX-N
9	1	BH-009	SSCUPSKT 0.138-32x0.25-HX-N
10	2	BH-010	HX-SHCS 0.112-40x0.25x0.25-N

		REVISIONS			
ZONE	REV.	DESCRIPTION	DATE	APPROVED	

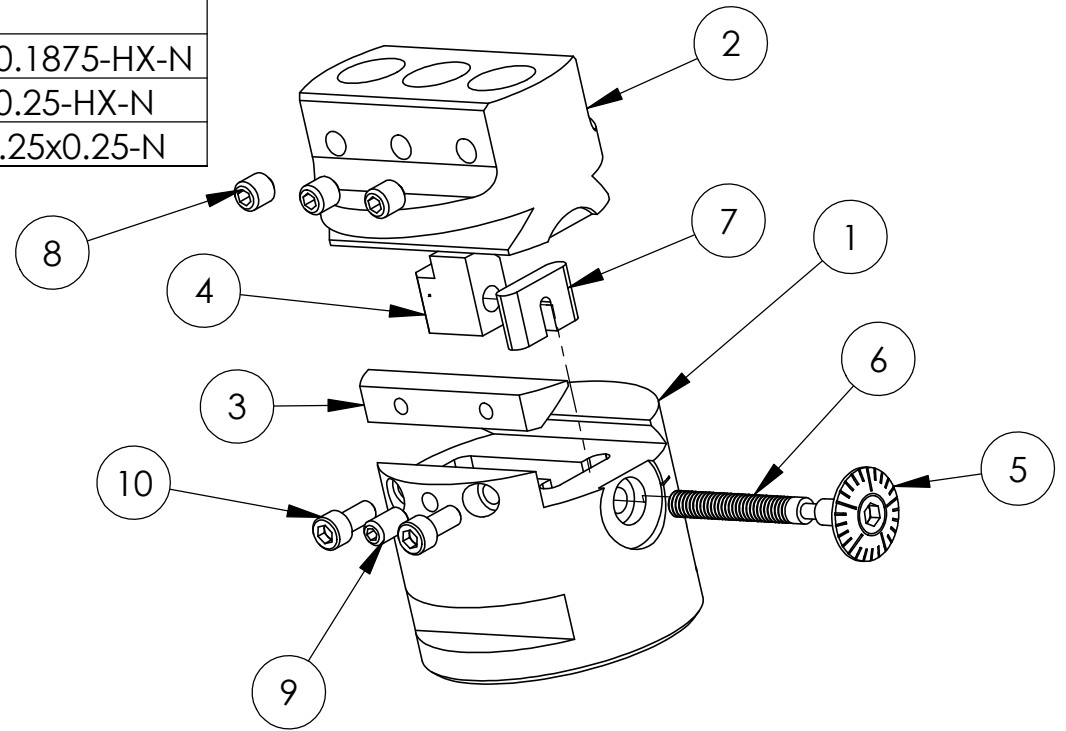
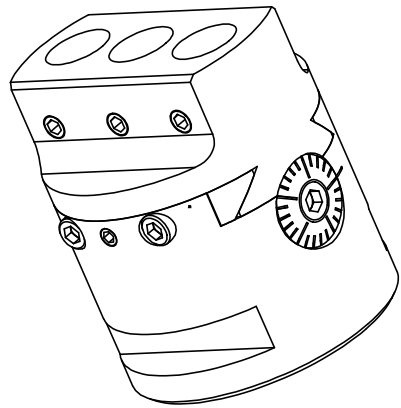

PROPRIETARY AND CONFIDENTIAL
 THE INFORMATION CONTAINED IN THIS DRAWING IS THE SOLE PROPERTY OF STEPHEN CAMPBELL. REPRODUCTION IN PART OR AS A WHOLE IS PERMITTED SO LONG IT IS NOT USED COMMERCIALY OR FOR PROFIT. TO DO SO IS PROHIBITED.

		UNLESS OTHERWISE SPECIFIED:	NAME	DATE	
		DIMENSIONS ARE IN INCHES	DRAWN	SCC	11/19/07
		TOLERANCES:	CHECKED		
		FRACTIONAL ±	ENG APPR.		
		ANGULAR: MACH ± BEND ±	MFG APPR.		
		TWO PLACE DECIMAL ±	Q.A.		
		THREE PLACE DECIMAL ±	COMMENTS:		
		INTERPRET GEOMETRIC TOLERANCING PER:			
		MATERIAL			
		FINISH			
	NEXT ASSY	USED ON			
	APPLICATION	DO NOT SCALE DRAWING			

TITLE: Boring Head Exploded View		
SIZE A	DWG. NO. 1210-001	REV
SCALE: 1:1	WEIGHT:	SHEET 1 OF 7

5

4

3

2

1

REVISIONS				
ZONE	REV.	DESCRIPTION	DATE	APPROVED

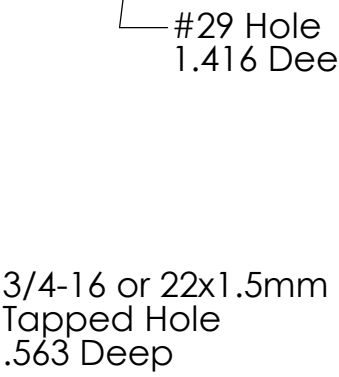
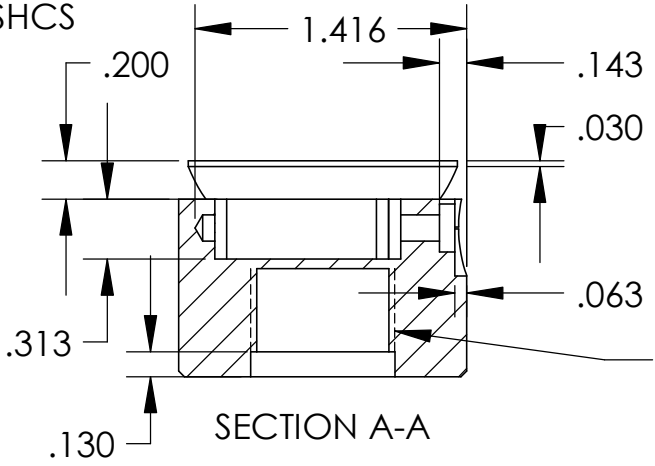
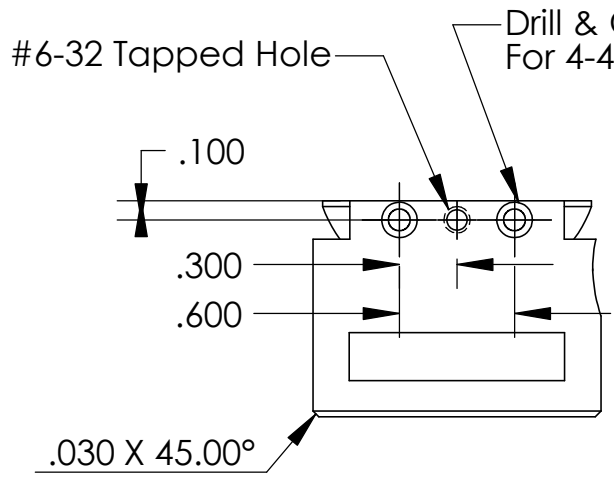
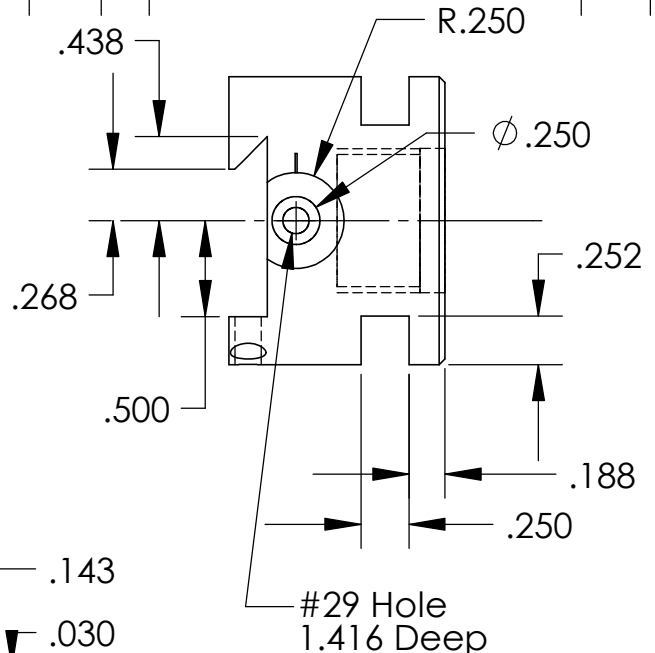
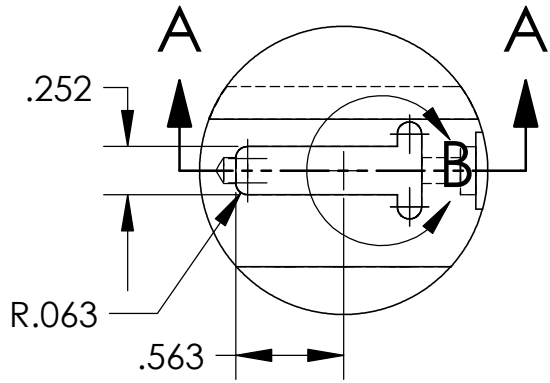
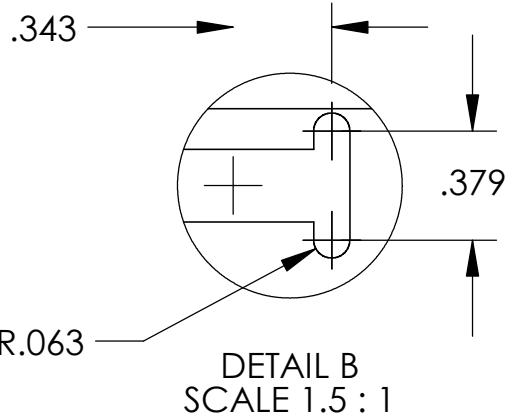

PROPRIETARY AND CONFIDENTIAL
THE INFORMATION CONTAINED IN THIS DRAWING IS THE SOLE PROPERTY OF STEPHEN CAMPBELL. REPRODUCTION IN PART OR AS A WHOLE IS PERMITTED SO LONG IT IS NOT USED COMMERCIALY OR FOR PROFIT. TO DO SO IS PROHIBITED.

		UNLESS OTHERWISE SPECIFIED:	NAME	DATE
		DIMENSIONS ARE IN INCHES	DRAWN	scc
		TOLERANCES:	CHECKED	11/19/07
		FRACTIONAL ±	ENG APPR.	
		ANGULAR: MACH ± BEND ±	MFG APPR.	
		TWO PLACE DECIMAL ±	Q.A.	
		THREE PLACE DECIMAL ±	COMMENTS:	
		INTERPRET GEOMETRIC TOLERANCING PER:		
		MATERIAL		
		12L14		
		FINISH		
NEXT ASSY	USED ON			
APPLICATION	DO NOT SCALE DRAWING			

TITLE: Boring Head Body		
SIZE A	DWG. NO. 1210-001	REV
SCALE: 1:1	WEIGHT:	SHEET 2 OF 7

NOTE: For max depth cut holes w/ .25" end mill then ream to .375"

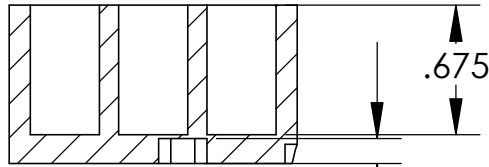

SECTION C-C

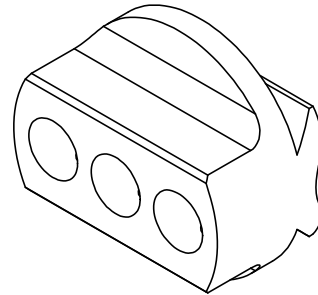
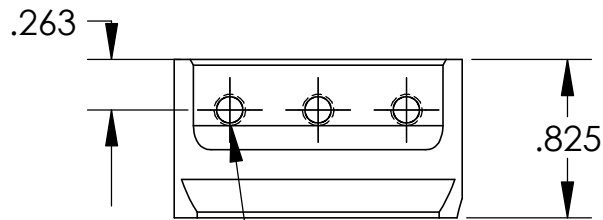
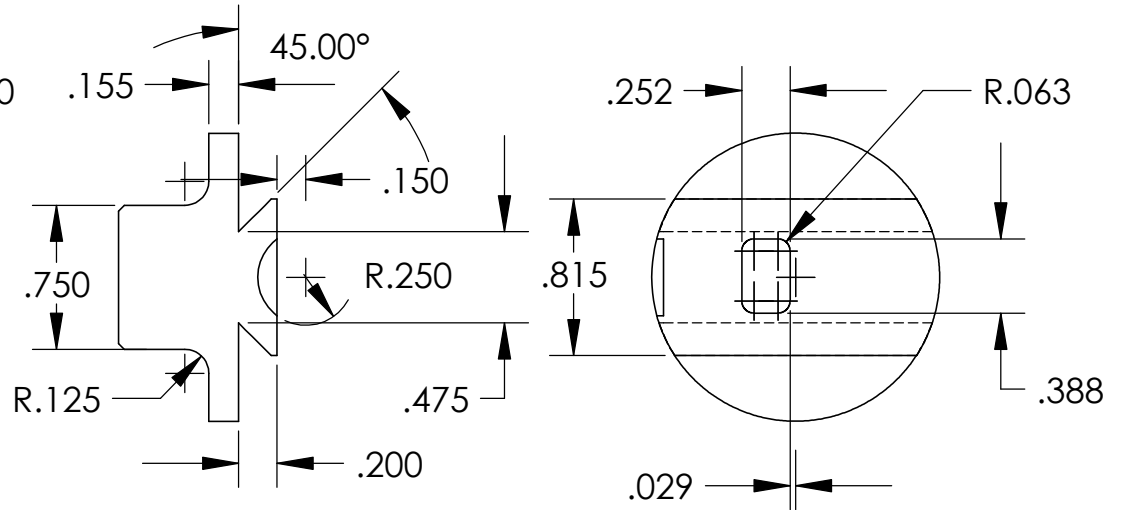
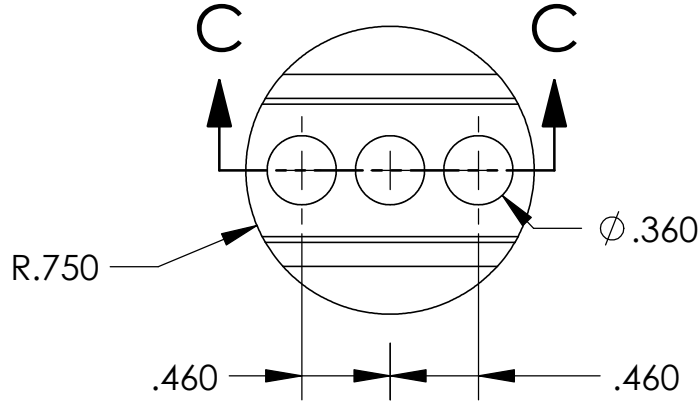

#8-32 Tapped Hole

REV. NO.		REVISIONS	DATE	APPROVED
ZONE	REV.	DESCRIPTION		

PROPRIETARY AND CONFIDENTIAL
 THE INFORMATION CONTAINED IN THIS DRAWING IS THE SOLE PROPERTY OF STEPHEN CAMPBELL. REPRODUCTION IN PART OR AS A WHOLE IS PERMITTED SO LONG IT IS NOT USED COMMERCIALY OR FOR PROFIT. TO DO SO IS PROHIBITED.

		UNLESS OTHERWISE SPECIFIED:	NAME	DATE
		DIMENSIONS ARE IN INCHES	DRAWN	scc 11/19/07
		TOLERANCES:	CHECKED	
		FRACTIONAL ±	ENG APPR.	
		ANGULAR: MACH ± BEND ±	MFG APPR.	
		TWO PLACE DECIMAL ±	Q.A.	
		THREE PLACE DECIMAL ±	COMMENTS:	
		INTERPRET GEOMETRIC TOLERANCING PER:		
		MATERIAL		
		12L14		
		FINISH		
NEXT ASSY	USED ON			
APPLICATION		DO NOT SCALE DRAWING		

TITLE:		
<h1>Slide</h1>		
SIZE	DWG. NO.	REV
A	1210-001	
SCALE: 1:1	WEIGHT:	SHEET 3 OF 7

REVISIONS		DATE	APPROVED
ZONE	REV.	DESCRIPTION	

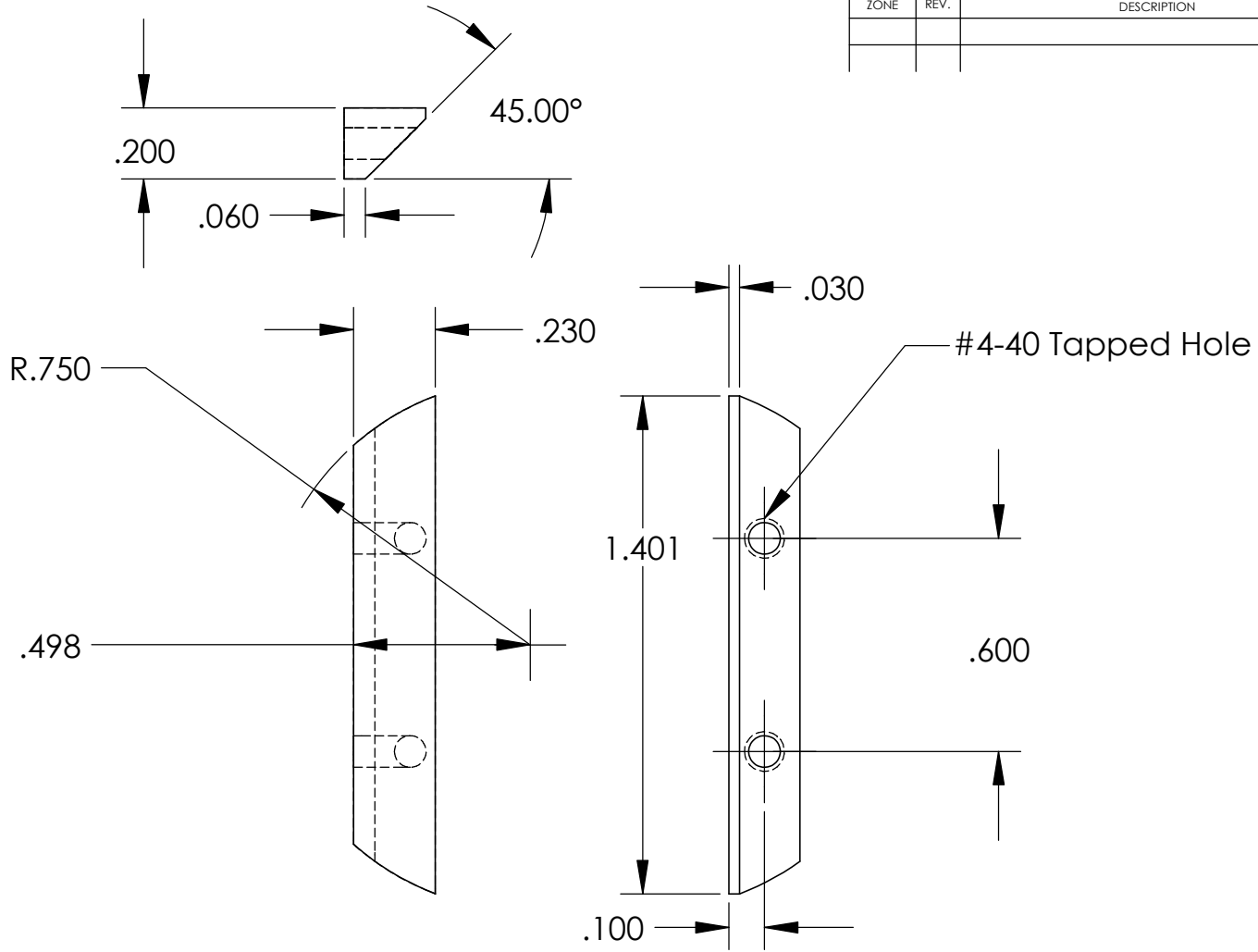

PROPRIETARY AND CONFIDENTIAL
 THE INFORMATION CONTAINED IN THIS DRAWING IS THE SOLE PROPERTY OF STEPHEN CAMPBELL. REPRODUCTION IN PART OR AS A WHOLE IS PERMITTED SO LONG IT IS NOT USED COMMERCIALY OR FOR PROFIT. TO DO SO IS PROHIBITED.

		UNLESS OTHERWISE SPECIFIED:	NAME	DATE	TITLE: Gib	
		DIMENSIONS ARE IN INCHES	DRAWN	scc		11/19/07
		TOLERANCES: FRACTIONAL ±	CHECKED			
		ANGULAR: MACH ± BEND ±	ENG APPR.			
		TWO PLACE DECIMAL ±	MFG APPR.			
		THREE PLACE DECIMAL ±	Q.A.			
		INTERPRET GEOMETRIC TOLERANCING PER:	COMMENTS:			
		MATERIAL Brass				
		FINISH				
NEXT ASSY	USED ON				SIZE A DWG. NO. 1210-001 REV	
APPLICATION		DO NOT SCALE DRAWING			SCALE: 2:1 WEIGHT: SHEET 4 OF 7	

REVISIONS		DATE	APPROVED
ZONE	REV.	DESCRIPTION	

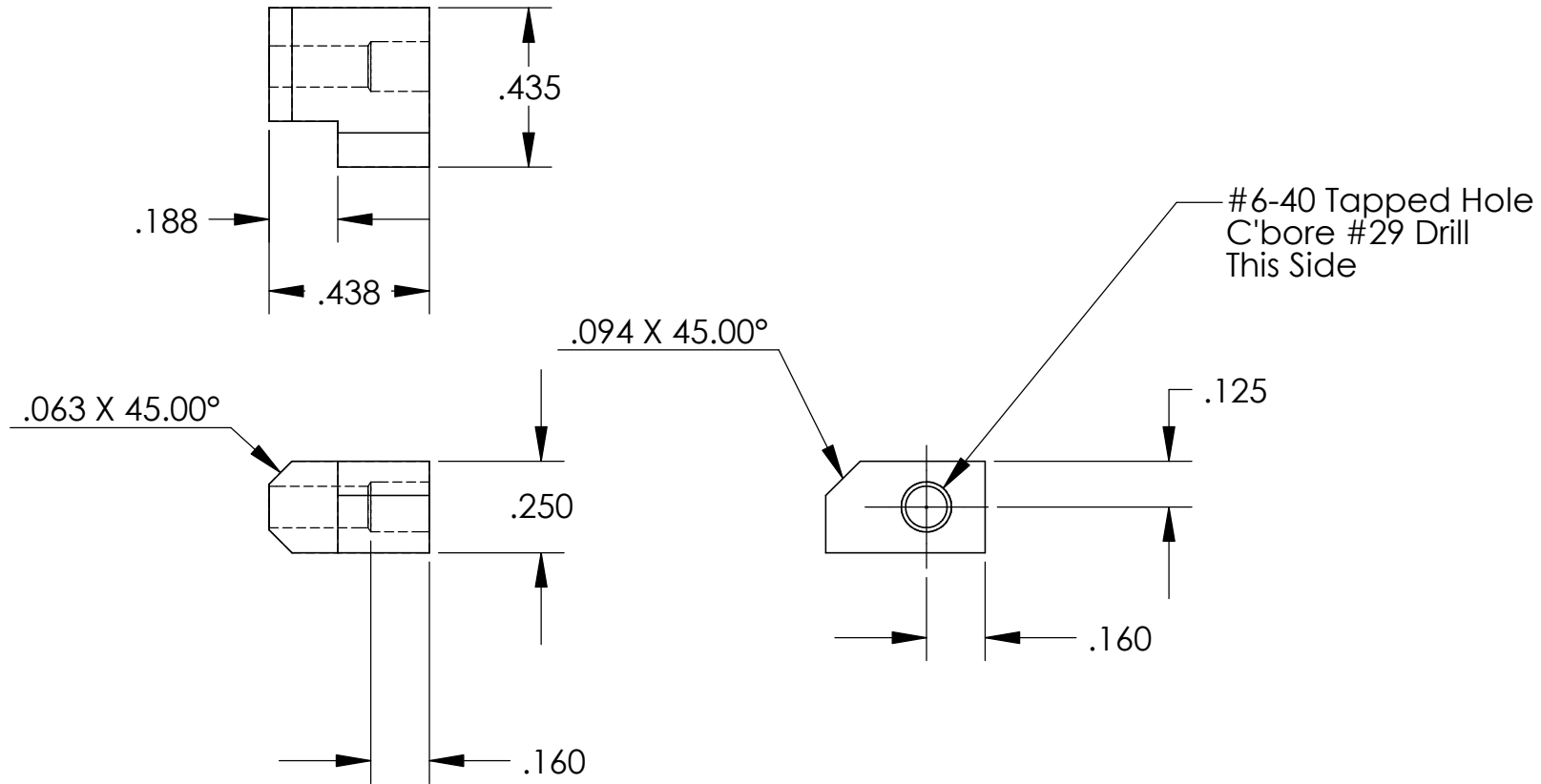

PROPRIETARY AND CONFIDENTIAL
 THE INFORMATION CONTAINED IN THIS DRAWING IS THE SOLE PROPERTY OF STEPHEN CAMPBELL. REPRODUCTION IN PART OR AS A WHOLE IS PERMITTED SO LONG IT IS NOT USED COMMERCIALY OR FOR PROFIT. TO DO SO IS PROHIBITED.

		UNLESS OTHERWISE SPECIFIED:		NAME	DATE	TITLE: <h1>Nut</h1>
		DIMENSIONS ARE IN INCHES	DRAWN	scc	11/19/07	
		TOLERANCES:	CHECKED			
		FRACTIONAL \pm	ENG APPR.			
		ANGULAR: MACH \pm BEND \pm	MFG APPR.			
		TWO PLACE DECIMAL \pm	Q.A.			SIZE DWG. NO. REV A 1210-001
		THREE PLACE DECIMAL \pm	COMMENTS:			
		INTERPRET GEOMETRIC TOLERANCING PER:				SCALE: 2:1 WEIGHT: SHEET 5 OF 7
		MATERIAL Brass				
		FINISH				
NEXT ASSY	USED ON					
APPLICATION		DO NOT SCALE DRAWING				

		REVISIONS			
ZONE	REV.	DESCRIPTION		DATE	APPROVED

Engrave Dial w/25 Divisions
Silver Solder to Modified Screw

Make From 6-40 UNF x 1.25
SHCS

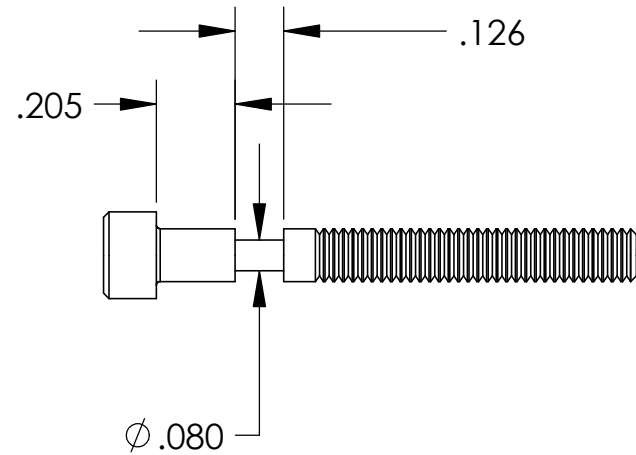
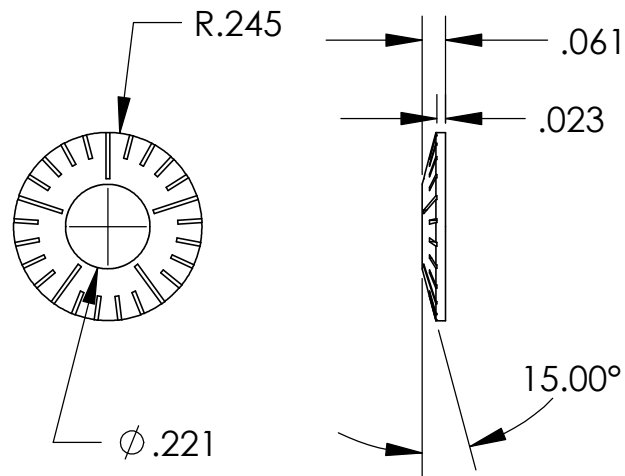

PROPRIETARY AND CONFIDENTIAL
THE INFORMATION CONTAINED IN THIS DRAWING IS THE SOLE PROPERTY OF STEPHEN CAMPBELL. REPRODUCTION IN PART OR AS A WHOLE IS PERMITTED SO LONG IT IS NOT USED COMMERCIALY OR FOR PROFIT. TO DO SO IS PROHIBITED.

		UNLESS OTHERWISE SPECIFIED:		NAME	DATE		
		DIMENSIONS ARE IN INCHES TOLERANCES: FRACTIONAL \pm ANGULAR: MACH \pm BEND \pm TWO PLACE DECIMAL \pm THREE PLACE DECIMAL \pm		DRAWN	scc	11/19/07	TITLE: Screw & Dial
		INTERPRET GEOMETRIC TOLERANCING PER:		CHECKED			
		MATERIAL Dial 12L14		ENG APPR.			
		FINISH		MFG APPR.			
NEXT ASSY	USED ON			Q.A.			SIZE DWG. NO. REV A 1210-001
APPLICATION		DO NOT SCALE DRAWING		COMMENTS:			
				SCALE: 2:1	WEIGHT:	SHEET 6 OF 7	

REVISIONS		DATE	APPROVED
ZONE	REV.	DESCRIPTION	

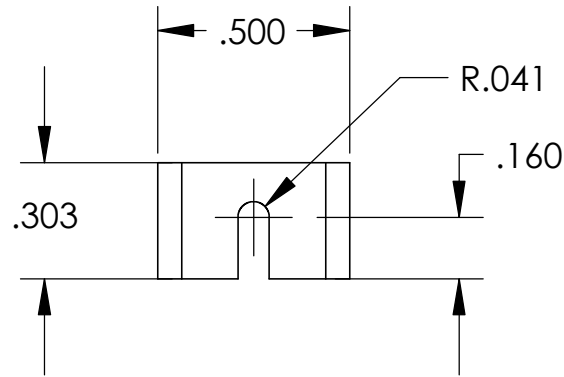
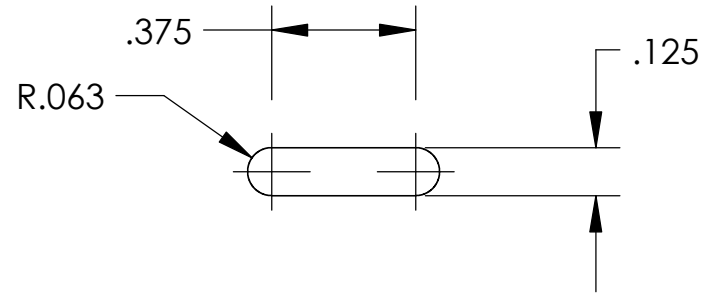

PROPRIETARY AND CONFIDENTIAL
 THE INFORMATION CONTAINED IN THIS DRAWING IS THE SOLE PROPERTY OF STEPHEN CAMPBELL. REPRODUCTION IN PART OR AS A WHOLE IS PERMITTED SO LONG IT IS NOT USED COMMERCIALY OR FOR PROFIT. TO DO SO IS PROHIBITED.

		UNLESS OTHERWISE SPECIFIED:		NAME	DATE	TITLE: Dial Retainer
		DIMENSIONS ARE IN INCHES	DRAWN	scc	11/19/07	
		TOLERANCES: FRACTIONAL ±	CHECKED			
		ANGULAR: MACH ± BEND ±	ENG APPR.			
		TWO PLACE DECIMAL ± THREE PLACE DECIMAL ±	MFG APPR.			
		INTERPRET GEOMETRIC TOLERANCING PER:	Q.A.			SIZE DWG. NO. REV A 1210-001
		MATERIAL Brass	COMMENTS:			
NEXT ASSY	USED ON	FINISH				
APPLICATION		DO NOT SCALE DRAWING				SCALE: 2:1 WEIGHT: SHEET 7 OF 7